



SLVU2.8-4

Ultralow Capacitance Transient Voltage Suppressors Array

General Description

The SLVU2.8-4 is in an SOP-8 package and may be used to protect two high-speed line pairs. The "flow-thru" design minimizes trace inductance and reduces voltage overshoot associated with ESD events. The low clamping voltage of the SLVU2.8-4 minimizes the stress on the protected IC.

Applications

- Ethernet – 10/100/1000 Base T
- WAN/LAN Equipment
- Desktops, Servers, Notebooks & Handhelds, base stations Laser Diode Protection

Features

- 400 W Peak Pulse Power per Line ($t_p=8/20\mu s$)
- Protects two line pairs (four lines).
- Low capacitance
- Low Leakage Current.
- Low Operating and Clamping Voltages.
- Transient Protection for High Speed Data Lines to IEC61000-4-2(ESD) $\pm 15kV(\text{air}), \pm 8kV(\text{Contact})$ IEC61000-4-4(EFT) 40A(5/50ns) IEC61000-4-5(lightning) 24A(8/20us)

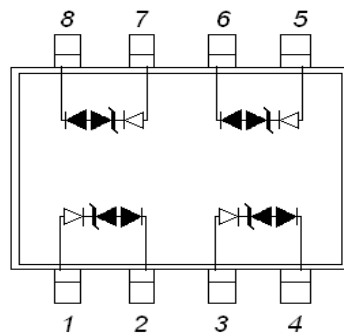
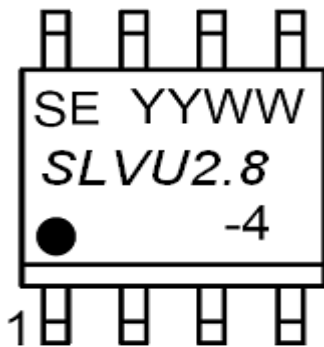

Absolute Maximum Ratings

Parameter	Symbol	Value	Units
Peak Pulse Power ($t_p = 8/20\mu s$) - See Fig1.	P_{PK}	400	W
Peak Pulse Current ($t_p = 8/20\mu s$)	I_{PP}	20	A
Storage Temperature Range	T_{STG}	-55 to 150	$^{\circ}C$
Operating Junction Temperature Range	T_J	-55 to 150	$^{\circ}C$

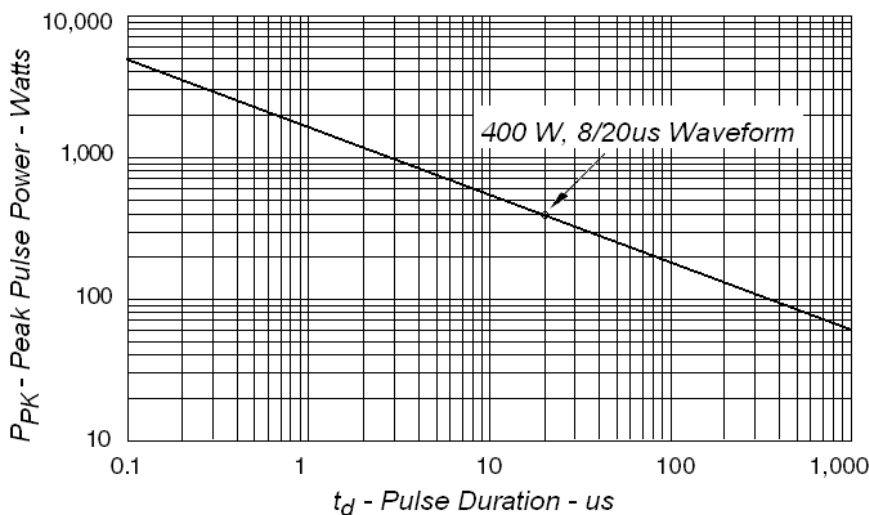

Fig1. Peak Pulse Power VS Pulse Time

Electrical Parameter

Symbol	Parameter
I_{PP}	Peak Pulse Current
V_C	Clamping Voltage @ I_{PP}
V_{RWM}	Reverse Stand-Off Voltage
I_R	Reverse Leakage Current @ V_{RWM}
V_{SB}	Snap-Back Voltage @ I_{SB}
I_{SB}	Snap-Back Current
V_{PT}	Punch-Through Voltage
I_{PT}	Punch-Through Current
V_{BRR}	Reverse Breakdown Voltage @ I_{BRR}
I_{BRR}	Reverse Breakdown Current

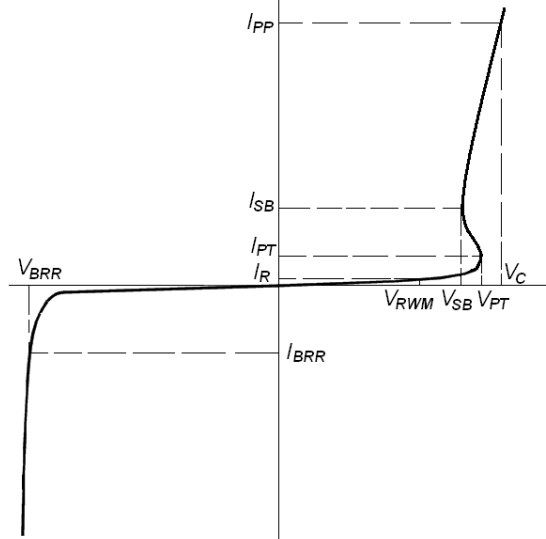

Fig2.

Electrical Characteristics

Parameter	Symbol	Conditions	Minimum	Typical	Maximum	Units
Reverse Stand-Off Voltage	V_{RWM}				2.8	V
Punch-Through Voltage	V_{PT}	$I_{PT} = 2\mu A$	2.8			V
Snap-Back Voltage	V_{SB}	$I_{SB} = 50mA$	2.8			V
Reverse Leakage Current	I_R	$V_{RWM} = 2.8V, T = 25^\circ C$ (Each Line)			1	μA
Clamping Voltage	V_C	$I_{PP} = 2A, t_p = 8/20\mu s$ (Each Line)			5.5	V
Clamping Voltage	V_C	$I_{PP} = 5A, t_p = 8/20\mu s$ (Each Line)			8.5	V
Clamping Voltage	V_C	$I_{PP} = 24A, t_p = 8/20\mu s$ (Each Line)			15	V
Junction Capacitance	C_j	$V_R = 0V, f = 1MHz$ (Each Line)		3.5	5	pF

Typical Characteristics

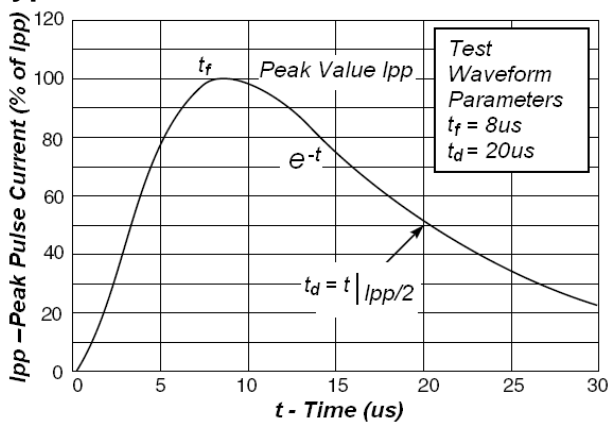

Fig3. Pulse Waveform

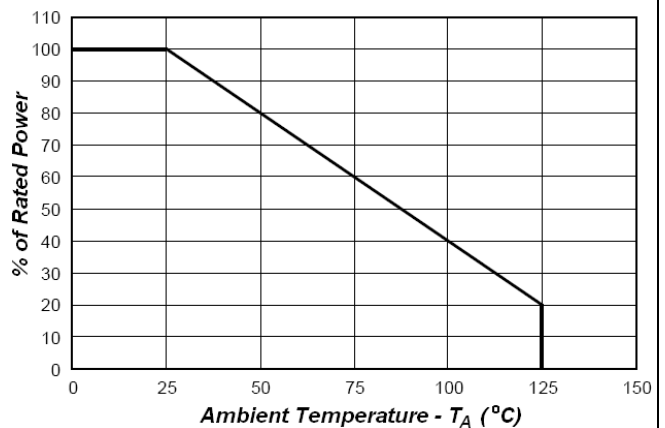

Fig4. Power Derating Curve

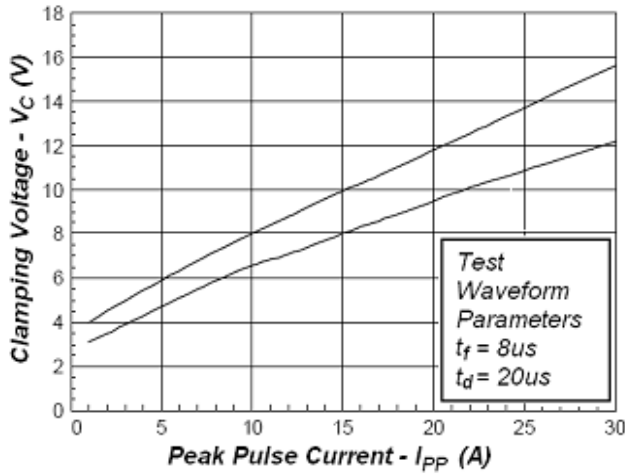

Fig5. Clamping Voltage vs. Peak Pulse Current

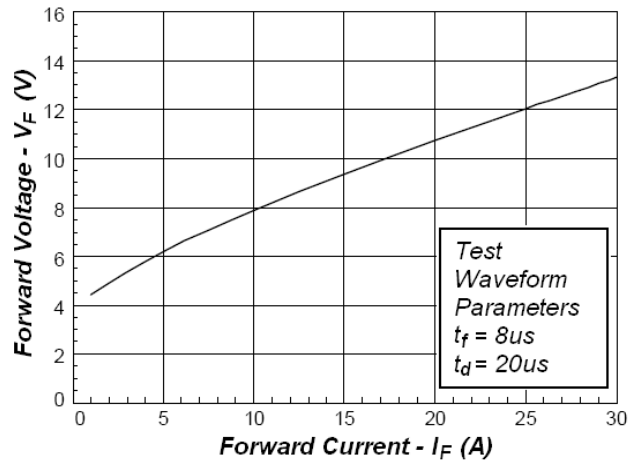

Fig6. Forward Voltage vs. Forward Current

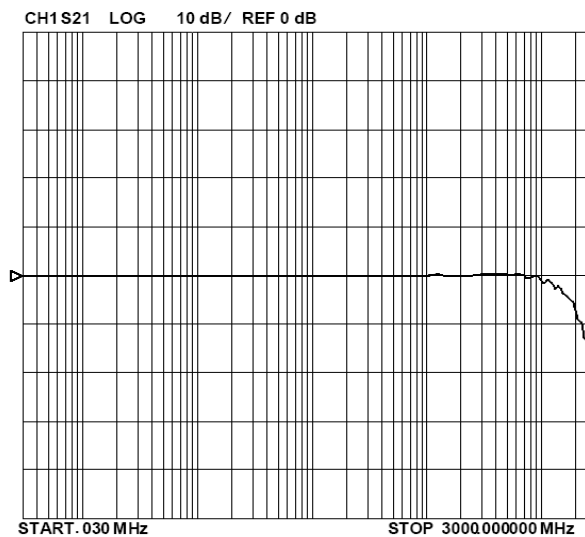

Fig7. Insertion Loss S21

Application Note

Electronic equipment is susceptible to damage caused by Electrostatic Discharge (ESD), Electrical Fast Transients (EFT), and tertiary lightning effects. Knowing that equipment can be damaged, the SLVU2.8-4 was designed to provide the level of protection required to safe guard sensitive equipment. This product can be used in different configurations to provide a level of protection to meet unidirectional line requirements as well as bidirectional requirements either in a common-mode or differential-mode configuration.

Unidirectional Common-Mode Protection (Figure 9)

The SLVU2.8-4 provides up to four lines of protection in a common-mode configuration as depicted in figure 9.

Circuit connectivity is as follows:

- Line 1 is connected to Pin 1
- Line 2 is connected to Pin 7
- Line 3 is connected to Pin 3
- Line 4 is connected to Pin 5
- Pins 2, 4, 7 and 8 are connected to ground

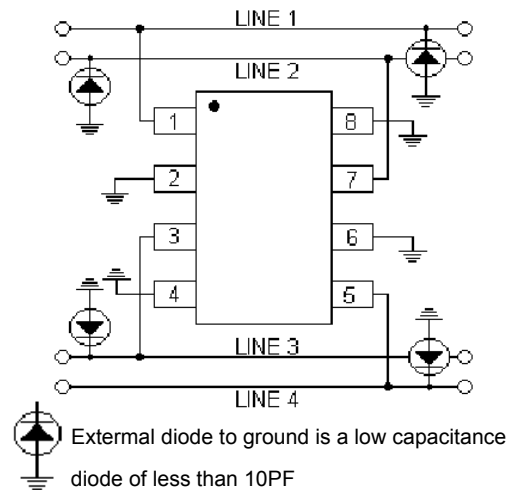

Fig9.

Bidirectional Common-Mode Protection (Figure 10)

The SLVU2.8-4 provides up to two lines of protection in a common-mode configuration as depicted in figure 10.

Circuit connectivity is as follows:

- Line 1 is connected to Pins 1 & 8
- Line 2 is connected to Pins 4 & 5
- Pins 2, 3, 6, and 7 are connected to ground

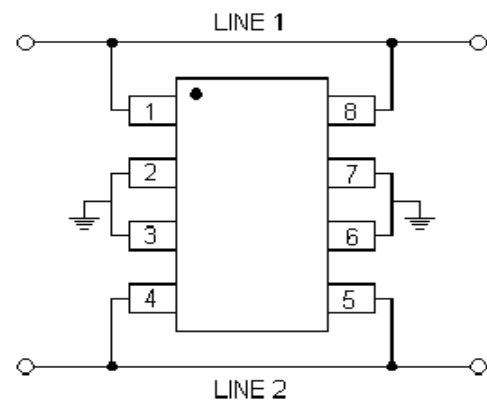

Fig10.

Bidirectional different-Mode Protection (Figure 11)

The SLVU2.8-4 provides up to two-line pairs of protection in a differential-mode configuration as depicted in figure 11.

Circuit connectivity is as follows:

- Line Pair 1 is connected to Pins 1 & 2
- Line Pair 1 is connected to Pins 7 & 8
- Line Pair 2 is connected to Pins 3 & 4
- Line Pair 2 is connected to Pins 5 & 6

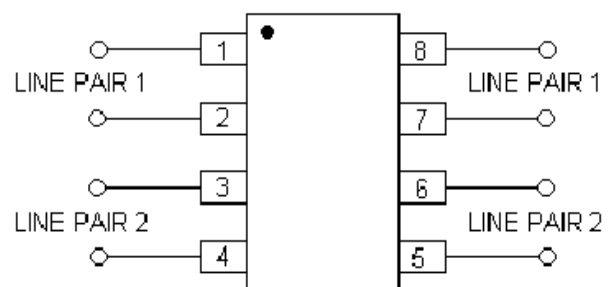

Fig11.

Circuit Board Layout Protection

Circuit board layout is critical for Electromagnetic Compatibility (EMC) protection. The following guidelines are recommended:

- The protection device should be placed near the input terminals or connectors, the device will divert the transient current immediately before it can be coupled into the nearby traces.
- The path length between the TVS device and the protected line should be minimized.
- All conductive loops including power and ground loops should be minimized.
- The transient current return path to ground should be kept as short as possible to reduce parasitic inductance.
- Ground planes should be used whenever possible. For multilayer PCBs, use ground vias.

Typical Applications

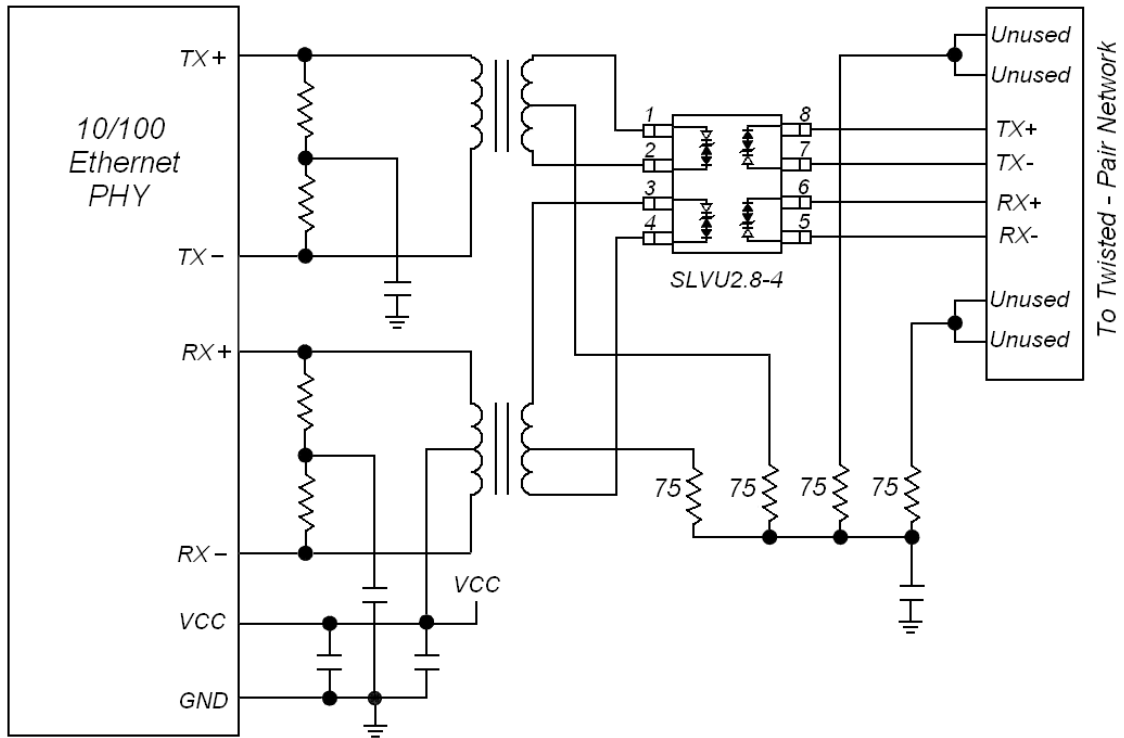

Fig12. 10/100 Ethernet Protection Circuit

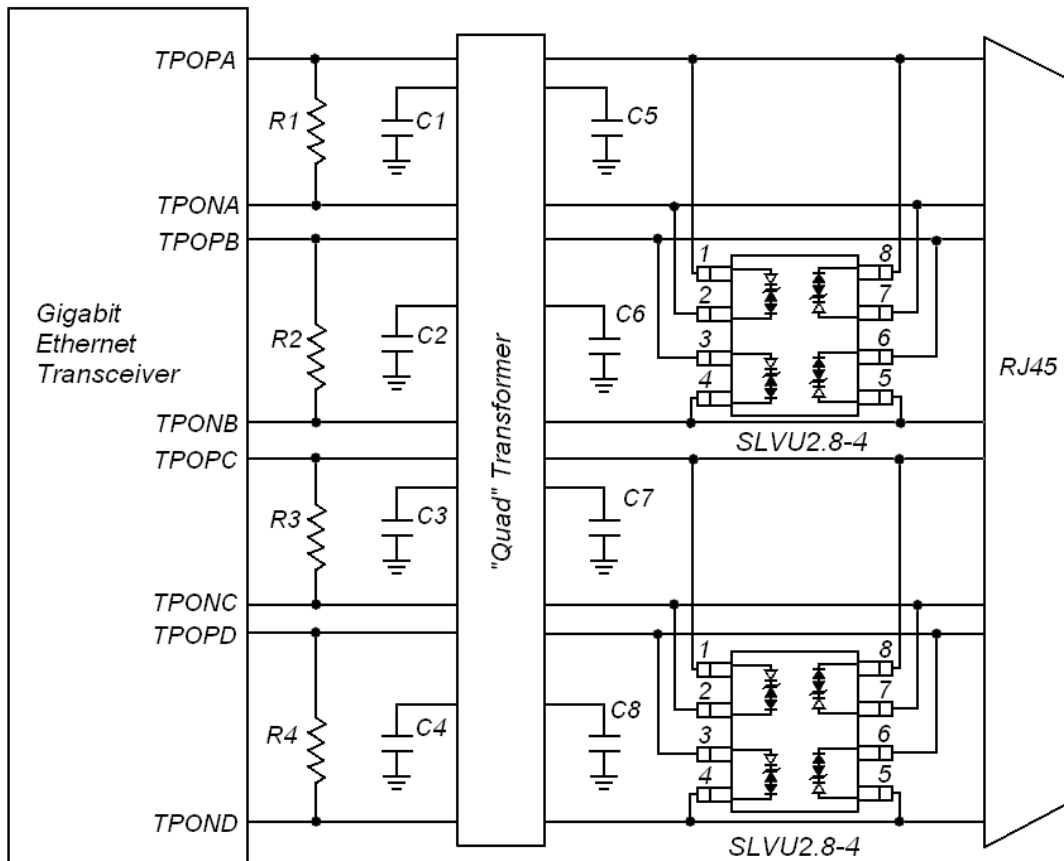

Fig13. Gigabit Ethernet Protection Circuit

SOP-8 MECHANICAL DATA

DIM	Millimeters		
	MIN	TYP	MAX
A			1.75
A1	0.10		0.25
A2	1.35	1.55	1.75
B	0.35	0.42	0.49
C	0.19		0.25
D	4.80	4.90	5.00
E	5.80	6.00	6.20
E1	3.80	3.95	4.00
e		1.27	
L	0.40		0.90
K	0°		8°

